



User manual and maintenance guide

Sliding gates



TECHNICAL FILE

In accordance with the enclosure V of **Machinery Directive 2006/42/CE**

In accordance with standards:

- **UNI EN 13241-1** (Product rule for industrial, commercial and garage doors and gates) in which reference is made to the following standards
- **UNI EN 12604** (Industrial, commercial and garage doors and gates rule, mechanical aspects : requirements).
- **UNI EN 12453** (Industrial, commercial and garage doors and gates rule, safety in use of power operated doors: requirements)
- **UNI EN 12635** (Industrial, commercial and garage doors and gates rule, Installation and use)

We remind you that whoever sells and powers a door/gate becomes the automatic door/gate/operator constructor and has to pre-dispose and keep the **technical file** which should include following documents.

- Analysis of the risks presented by the door/gate and description of adopted solutions (*make use of "analysis of risks" forms, to be filled in*).
- Door/gate overall drawing and table of the electrical connections and control circuits (*make use of "ensemble drawing - electrical table", to be filled in*).
- Draw up the CE declaration of conformity (attaching the declarations of conformity of single installed components) and deliver to the user (*make use of "declaration of conformity" form, to be filled in*).
- Draw up the maintenance book and deliver copy to the user (*make use of "maintenance book" form, to be filled in*).
- Deliver to the final user all instructions for the unlocking system use and general safety advertising (*every instruction and maintenance manual coupled to DEA SYSTEM devices is provided with a detachable insert to be delivered to the final user*).

NOTE: Technical file should be kept at disposal of national competent authorities for at least ten years from the door/gate construction date.

Type of installation: <input type="checkbox"/> Sliding gate <input type="checkbox"/> Wing door <input type="checkbox"/> Folding door <input type="checkbox"/> Sectional door <input type="checkbox"/> Spring door <input type="checkbox"/> Barrier <input type="checkbox"/> ...		Type of automation <table style="width: 100%; border: none;"> <tr> <td style="width: 50%; border: none; vertical-align: top;"> <input type="checkbox"/> LIVI/X <input type="checkbox"/> REV <input type="checkbox"/> GULLIVER/N <input type="checkbox"/> MAC <input type="checkbox"/> STING <input type="checkbox"/> LOOK <input type="checkbox"/> OLI/N <input type="checkbox"/> GEKO <input type="checkbox"/> LIVI 502 <input type="checkbox"/> ANGOLO <input type="checkbox"/> GHOST 100 <input type="checkbox"/> GHOST 200 </td> <td style="width: 50%; border: none; vertical-align: top;"> <input type="checkbox"/> LIVI 902 <input type="checkbox"/> ADVANCE/N <input type="checkbox"/> SPACE/N <input type="checkbox"/> TEO 700 <input type="checkbox"/> LATO <input type="checkbox"/> LIVI 550 PL <input type="checkbox"/> WILL 140 E <input type="checkbox"/> PASS/N <input type="checkbox"/> STOP/N <input type="checkbox"/> TRAFIK/N <input type="checkbox"/> ROCK </td> </tr> </table>		<input type="checkbox"/> LIVI/X <input type="checkbox"/> REV <input type="checkbox"/> GULLIVER/N <input type="checkbox"/> MAC <input type="checkbox"/> STING <input type="checkbox"/> LOOK <input type="checkbox"/> OLI/N <input type="checkbox"/> GEKO <input type="checkbox"/> LIVI 502 <input type="checkbox"/> ANGOLO <input type="checkbox"/> GHOST 100 <input type="checkbox"/> GHOST 200	<input type="checkbox"/> LIVI 902 <input type="checkbox"/> ADVANCE/N <input type="checkbox"/> SPACE/N <input type="checkbox"/> TEO 700 <input type="checkbox"/> LATO <input type="checkbox"/> LIVI 550 PL <input type="checkbox"/> WILL 140 E <input type="checkbox"/> PASS/N <input type="checkbox"/> STOP/N <input type="checkbox"/> TRAFIK/N <input type="checkbox"/> ROCK	Automation lable data <table border="1" style="width: 100%; border-collapse: collapse;"> <tr><th colspan="2" style="text-align: center;">Automation 1</th></tr> <tr><td style="width: 30%;">Type:</td><td></td></tr> <tr><td>Code:</td><td></td></tr> <tr><td>Rev.:</td><td></td></tr> <tr><td>Serial N.</td><td></td></tr> <tr><td>Month:</td><td></td></tr> <tr><td>Year:</td><td></td></tr> </table> <table border="1" style="width: 100%; border-collapse: collapse;"> <tr><th colspan="2" style="text-align: center;">Automation 2 if present</th></tr> <tr><td style="width: 30%;">Type:</td><td></td></tr> <tr><td>Code:</td><td></td></tr> <tr><td>Rev.:</td><td></td></tr> <tr><td>Serial N.</td><td></td></tr> <tr><td>Month:</td><td></td></tr> <tr><td>Year:</td><td></td></tr> </table>		Automation 1		Type:		Code:		Rev.:		Serial N.		Month:		Year:		Automation 2 if present		Type:		Code:		Rev.:		Serial N.		Month:		Year:	
<input type="checkbox"/> LIVI/X <input type="checkbox"/> REV <input type="checkbox"/> GULLIVER/N <input type="checkbox"/> MAC <input type="checkbox"/> STING <input type="checkbox"/> LOOK <input type="checkbox"/> OLI/N <input type="checkbox"/> GEKO <input type="checkbox"/> LIVI 502 <input type="checkbox"/> ANGOLO <input type="checkbox"/> GHOST 100 <input type="checkbox"/> GHOST 200	<input type="checkbox"/> LIVI 902 <input type="checkbox"/> ADVANCE/N <input type="checkbox"/> SPACE/N <input type="checkbox"/> TEO 700 <input type="checkbox"/> LATO <input type="checkbox"/> LIVI 550 PL <input type="checkbox"/> WILL 140 E <input type="checkbox"/> PASS/N <input type="checkbox"/> STOP/N <input type="checkbox"/> TRAFIK/N <input type="checkbox"/> ROCK																																		
Automation 1																																			
Type:																																			
Code:																																			
Rev.:																																			
Serial N.																																			
Month:																																			
Year:																																			
Automation 2 if present																																			
Type:																																			
Code:																																			
Rev.:																																			
Serial N.																																			
Month:																																			
Year:																																			
Installation finishing date:	Unique Identification No.:																																		
Installing references	Installing firm Address Installing name and surname		Stamp																																
Door/gate references	Gate owner's name Address																																		

Documentation provided by **DEA System S.p.A.** for installing its products.

DEA doesn't assume any responsibility for errors or damages to items or persons.

© Copyright - All rights reserved - Unauthorized copying, even if partial, prohibited

RISKS ANALYSIS

SLIDING GATE

In accordance with the enclosure V of **Machinery Directive 2006/42/CE**

In accordance with standards:

- **UNI EN 13241-1** (Industrial doors and gates: Product Rule) in which reference is made to following standards
- **UNI EN 12604** Industrial, commercial and garage doors and gates standard, mechanical aspects: requirements)
- **UNI EN 12453** Industrial, commercial, garage doors and gates standard, safety in use of power operated doors: requirements
- **UNI EN 12635** Industrial, commercial and garage doors and gates standard, installation and use

INSPECTIONS TO BE DONE ON THE STRUCTURE OF THE DOOR WHICH HAS TO BE AUTOMATED

Verify that the door supports the opening and closing movements without permanent deformations which influence the functioning. Make the door perform ten complete opening manoeuvres and ten complete closing manoeuvres at an operative speed and with a force not greater than: - 225N (~22,5 Kg) for garage doors in private areas - 390N (~39 Kg) for industrial/commercial doors Possible anomalies must be adjusted.	Verified <input type="checkbox"/>	NOT applicable <input type="checkbox"/>
After these test cycles, shape or dimensions deformations or wear traces do not have to appear.	Verified <input type="checkbox"/>	NOT applicable <input type="checkbox"/>

RISKS OF CRUSHING, SHEARING, GUIDING, RAISING AND IMPACT.

1) Identify the minimum protection level of the primary requested edge which is to be adopted in different installing situations.

Activation commands type	MINIMUM PROTECTION LEVEL OF PRIMARY EDGE					
	Informed customers (private area)		Informed customers (public area)		Non informed customers	
Presence man function	Push button control	<input type="checkbox"/>	Key switch control	<input type="checkbox"/>	Presence man function is not possible	<input type="checkbox"/>
Impulse command at door sight	Force limitation, or presence detectors	<input type="checkbox"/>	Force limitation, or presence detectors	<input type="checkbox"/>	Force limitation and photocells, or presence detectors	<input type="checkbox"/>
Impulse command with door not at sight	Force limitation, or presence detectors	<input type="checkbox"/>	Force limitation and photocells, or presence detectors	<input type="checkbox"/>	Force limitation and photocells, or presence detectors	<input type="checkbox"/>
Automatic command (e.g. closing temporized command)	Force limitation and photocells, or presence detectors	<input type="checkbox"/>	Force limitation and photocells, or presence detectors	<input type="checkbox"/>	Force limitation and photocells, or presence detectors	<input type="checkbox"/>

2) Identify the risk areas

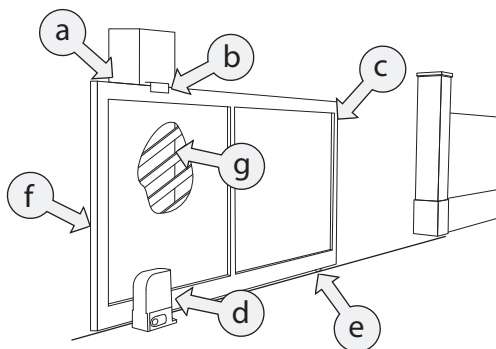

Fill in the table below adding the danger marks discovered (the typical ones are already listed) and the marks of adopted protection devices

Risk point/area	Verified danger						Safeguards to be adopted	Adopted protection (insert correspondent mark)							
a	3						(S1) o (S2)								
b	3						(S1) o (S2)								
c	1	5					(S4) o (S5+S6) o (S7)								
d	3						(S2)								
e	3						(S1) o (S2)								
f	1	5					(S4) o (S5+S6) o (S7)								
g	2						(S2) o (S5+S6)								
Other															
	1= Crashing 2= Shearing 3= Convoing 4= Raising 5= Impact 6= Other						S1 = Safety distances S2 = Shelters S3 = Surfaces modelling S4 = Human presence command S5 = Forces limitation (safety ribs or control panels with anti-crushing device) S6= Photocells S7 = Presence detector devices (sensitive platforms) S8 = Others								

3) Verify protections (only the ones adopted)

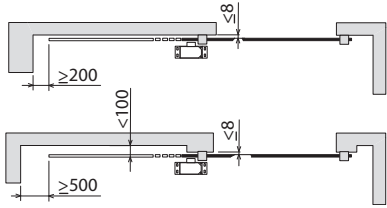
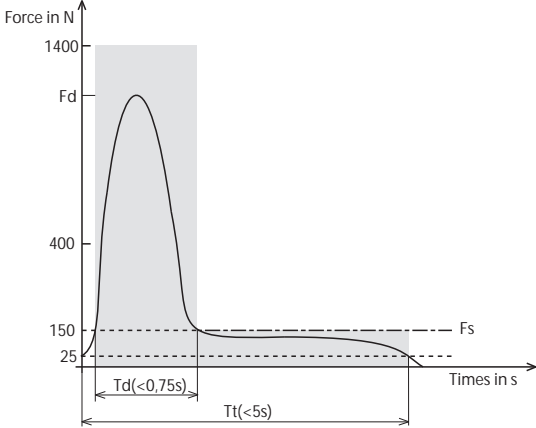
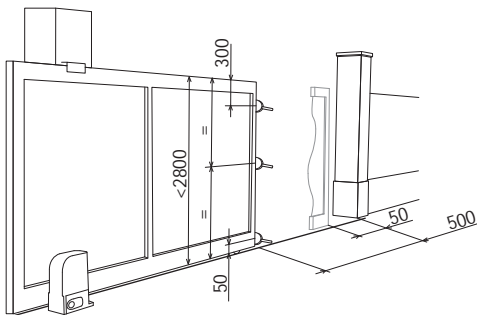
S1 Safety distances	<p>Check that distances regarding risk areas shown in figure are respected. For other risk points, security distances (min or max) have to be opportunely evaluated making reference to body parts which can really have access at the risk point.</p>	 <p style="text-align: center;">UPPER VIEW</p>	Verified <input type="checkbox"/>	NOT applicable <input type="checkbox"/>
S2 Guards	<p>Eventual adopted guards have to be checked by inspection, making sure that there isn't any lacking protection danger until a height of 2.5 mt. from the floor. Protections have:</p> <ul style="list-style-type: none"> - to resist to hurts (referring to their function) - to be loosened only by an instrument - not to create additional dangers - not to be easily neutralized, ignored or be ineffective. 	Verified <input type="checkbox"/>	NOT applicable <input type="checkbox"/>	
	<p>Verify that spacing between pinion and rack is adequately protected: in case apply a rubber profile to avoid fingers insertion.</p>	Verified <input type="checkbox"/>	NOT applicable <input type="checkbox"/>	
	<p>Verify that gate surfaces and next fencing aren't opened, in this case apply close-mesh net or punched sheet. Mesh net should be of proper dimensions, considering the body parts which can enter.</p>	Verified <input type="checkbox"/>	NOT applicable <input type="checkbox"/>	
S3 Modelling	<p>Eventual other guards....</p> <p>Verify that there are no surfaces presenting sharp edges which may cause lesions. Verify that there are no protruding parts which may cause lesions. In case, apply rubber protections to avoid these risks.</p>	Verified <input type="checkbox"/>	NOT applicable <input type="checkbox"/>	
S4 Presence man command	<p>Verify that manual actuators (e.g. keyswitch) are positioned so to avoid a dangerous position for whoever actuates them and are protected so to avoid any un-intentional action</p>	Verified <input type="checkbox"/>	NOT applicable <input type="checkbox"/>	
S5 Force limitation	<p>Verify that generated forces (measured with the instrument imposed by EN12453) are lower than what specified in the diagram.</p> <p>Closing and opening forces are measured in points as indicated depending on the door height:</p> <ul style="list-style-type: none"> - Door height lower than 2.8 mt. - Door height more than 2,8 mt. <p>Every measurement has to be the average of three readings. Repeat for each point force measuring with opened door of 50, 300, and 500 mm. Execute measuring also between the wing back edge and the rigid parts near the surrounding environment with the same frequency adopted for the primary edge. Measure direction has to be perpendicular to measure instrument disc.</p> <p>Besides, measures have to be taken on a complete door, completely equipped, with all built-in safety devices and adjusted as specified in manufacturer instructions.</p> <p>Shearing dangers on secondary edges (e.g. between the pillar and the edges of eventual slits on the door) can be safeguarded with forces limitation only if there is a distance of at least 25 mm. between the superimposed edges.</p> <p>Guiding, unlike thrust, cannot be safeguarded with the panel's torque adjustment.</p>	 	Verified <input type="checkbox"/>	NOT applicable <input type="checkbox"/>

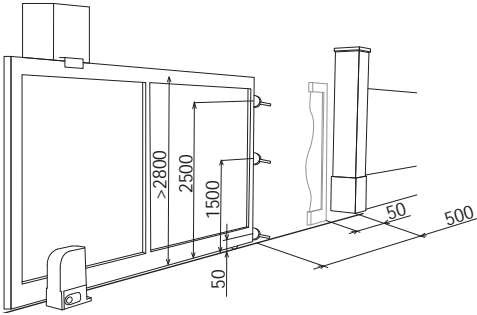
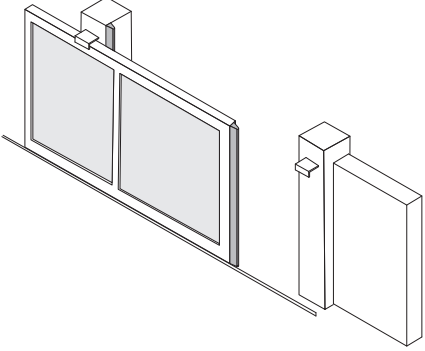
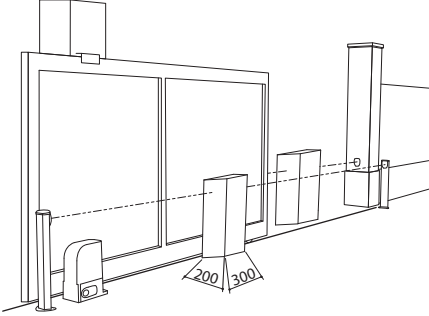
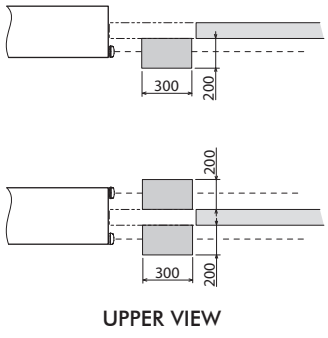
S5 Force limitation				
	<p>In case the automation doesn't have an internal device to limit the forces, it is possible to adopt some external devices, for example safety ribs (conformable with EN 12978), as shown. Measure impact forces as over mentioned too.</p> 	<p>Verified <input type="checkbox"/></p> <p>NOT applicable <input type="checkbox"/></p>		
	<p>Check that devices used to limit forces or to detect presence must avoid that dangerous situations happen also in case of a single failure. Forces limitations devices, included in DEA System control boards, the NET range, grant the respect of this requirement in accordance with EN 12453. Any other external forces limitation devices, electro-sensitive (ESPE) or sensitive to pressure (PSPE), must be in accordance with EN 12978.</p>	<p>Verified <input type="checkbox"/></p> <p>NOT applicable <input type="checkbox"/></p>		
S6 S7 Photocells	<p>Install a pair of photocells outside the door and check for correct functioning. For these inspections, a test instrument has to be used. It is a rigid object with dimensions 700 mm. x 300 mm. x 200 mm., with 3 opaque sides and 3 reflecting (1 for each dimension). Place the test instrument as follows: it has to be placed in the detection area of the safety device so that it would stop and reverse the movement of the door (or to avoid start of movement of a stopped door). When photocells on both sides are adopted (e.g. when children may have impacts with the doors) verify that there isn't any conflict between the two sides.</p>		<p>Verified <input type="checkbox"/></p> <p>NOT applicable <input type="checkbox"/></p>	
	 <p>UPPER VIEW</p>			
S8 Detector devices	<p>Presence detector devices, whether they are pressure sensitive (PSPE e.g. sensitive platforms) or electro-sensitive (ESPE e.g. photoelectrical barriers), have to avoid the occurrence of dangerous situations even in case of single failure (see EN 12978). Evaluation tests of a suitable safeguard level of devices which prevent in any case a contact between the door while moving and a person, are described at point 5.2.1.8 of EN12453. This test is not carried out any more specifically because it is more convenient using a force limitation, available when adopting DEA System driving units able to offer the requested safeguard level (series NET).</p>	<p>Verified <input type="checkbox"/></p> <p>NOT applicable <input type="checkbox"/></p>		

RISKS RESULTING FROM FEEDING AND DRIVING UNITS			
	Check that electrical automation is conformable with standard LVD (2014/35/EU).	Verified <input type="checkbox"/>	NOT applicable <input type="checkbox"/>
	Verify that hydraulic drive units adopted are conformable with EN 982.	Verified <input type="checkbox"/>	NOT applicable <input type="checkbox"/>
	Verify that electrical appliances, except from driving units, are projected and constructed as foreseen in EN 60204-1 ("Machinery safety, Machinery electrical equipment")	Verified <input type="checkbox"/>	NOT applicable <input type="checkbox"/>
	Verify that there is a power interruption device (omni-polar switch, socket connection, etc...). It is important to safeguard this device from non intentional or non authorised connection (e.g. protect from improper use by children).	Verified <input type="checkbox"/>	NOT applicable <input type="checkbox"/>
	Verify that after a failure or a power interruption, drive may start functioning without generating dangerous situations.	Verified <input type="checkbox"/>	NOT applicable <input type="checkbox"/>
	Verify that after driving unit deactivation or power interruption, the door: - stops in a space lower than 50 mm. if opening space is lower than 500 mm. - stops in a space lower than 100 mm. if opening space is more than 500 mm. - If this is not possible, a deformable edge must be present (its deformation must be higher than 50 mm. in the first case and higher than 100 mm. in the second case) and do not have to exercise a static force more than 150N (~15 Kg) on a tester of 80 mm. diameter.	Verified <input type="checkbox"/>	NOT applicable <input type="checkbox"/>
	Verify that drive destined to moving the door is conformable to standard EMCD (2014/30/EU).	Verified <input type="checkbox"/>	NOT applicable <input type="checkbox"/>
RISKS RESULTING FROM MANUAL OPERATION			
	Verify correct functioning of unlocking system.	Verified <input type="checkbox"/>	NOT applicable <input type="checkbox"/>
	Check if doors are provided with handles, projections or handrail which permit manual working, placed so to avoid dangers like crashing, shearing, guiding, etc.	Verified <input type="checkbox"/>	NOT applicable <input type="checkbox"/>
	Verify that when activating the door by hand, the human physical effort doesn't exceed following figures: - 225N (~22.5 Kg.) for private areas garage doors. - 390N (~39 Kg.) for industrial/commercial doors.	Verified <input type="checkbox"/>	NOT applicable <input type="checkbox"/>
RISKS RESULTING FROM THE PRESENCE OF GATES/DOORS FOR PEDESTRIAN ACCESS			
	Check that, if a supplementary door is installed on the gate, and it can be opened while gate moves, a limit switch is adopted to grant that door remains closed while gates moves and to maintain the protection even in case of switch failure.	Verified <input type="checkbox"/>	NOT applicable <input type="checkbox"/>
TRAPPING RISKS			
	Check that it is possible to manually move the door using an easily reachable unlocking system.	Verified <input type="checkbox"/>	NOT applicable <input type="checkbox"/>
FALLING OR INVOLUNTARY MOVEMENT RISKS			
	Verify that door safety stop on limit switches.	Verified <input type="checkbox"/>	NOT applicable <input type="checkbox"/>
	Check that door doesn't perform a non intentional movement (e.g. exit from guides or falling down due to intensive use).	Verified <input type="checkbox"/>	NOT applicable <input type="checkbox"/>
ADDITIONAL PRECAUTIONS			
	It is proper to adopt additional precautions, e.g.: - Lighting door area - Positioning notices to inform about the presence of an automatic door - Installing flashing lights - Yellow and black stickers to signal remaining risks	Executed <input type="checkbox"/>	NOT applicable <input type="checkbox"/>

ADDITIONAL DUTIES

<p>Place a label with CE marking and identifying data as shown.</p>	<div style="border: 1px solid black; padding: 10px; width: fit-content; margin: auto;"> <p>Product Rule EN 13241-1 (CPR 305/2011; 2006/42/CE; 2014/30/EU; 2014/35/EU) CE</p> <p> Door driver</p> <p>Installer (name-address): _____</p> <p>_____</p> <p>Type of door: _____</p> <p>Identifying number: _____</p> <p>Construction year: _____</p> </div>	<p>Executed</p> <input type="checkbox"/>	<p>NOT applicable</p> <input type="checkbox"/>
<p>Deliver to final user barrier instructions e.g. how to use unlocking systems. Inside instructions and maintenance manuals coupled to DEA devices, a detachable insert is included.</p>		<p>Executed</p> <input type="checkbox"/>	<p>NOT applicable</p> <input type="checkbox"/>
<p>Deliver to final user the Declaration of Conformity CE.</p>		<p>Executed</p> <input type="checkbox"/>	<p>NOT applicable</p> <input type="checkbox"/>
<p>Give to final customer a maintenance program to be followed to ensure the safe and efficient operation of the system. Inform the customer about remaining risks and how they have been pointed out.</p>		<p>Executed</p> <input type="checkbox"/>	<p>NOT applicable</p> <input type="checkbox"/>

Documentation provided by DEA System S.p.A. for installing its products.

DEA doesn't assume any responsibility for errors or damages to items or persons.

© Copyright - All rights reserved - Unauthorized copying, even if partial, prohibited

**ENSEMBLE DRAWING
ELECTRICAL SCHEM**

SLIDING GATE

The reproduced drawing represents a generic installation.

Nevertheless, components choice and arrangement is a consequence of decisions arrived at during the risks analysis. Therefore, in the table, do not indicate unused components but add (in drawing also) other necessary devices added as a consequence of the risk analysis.

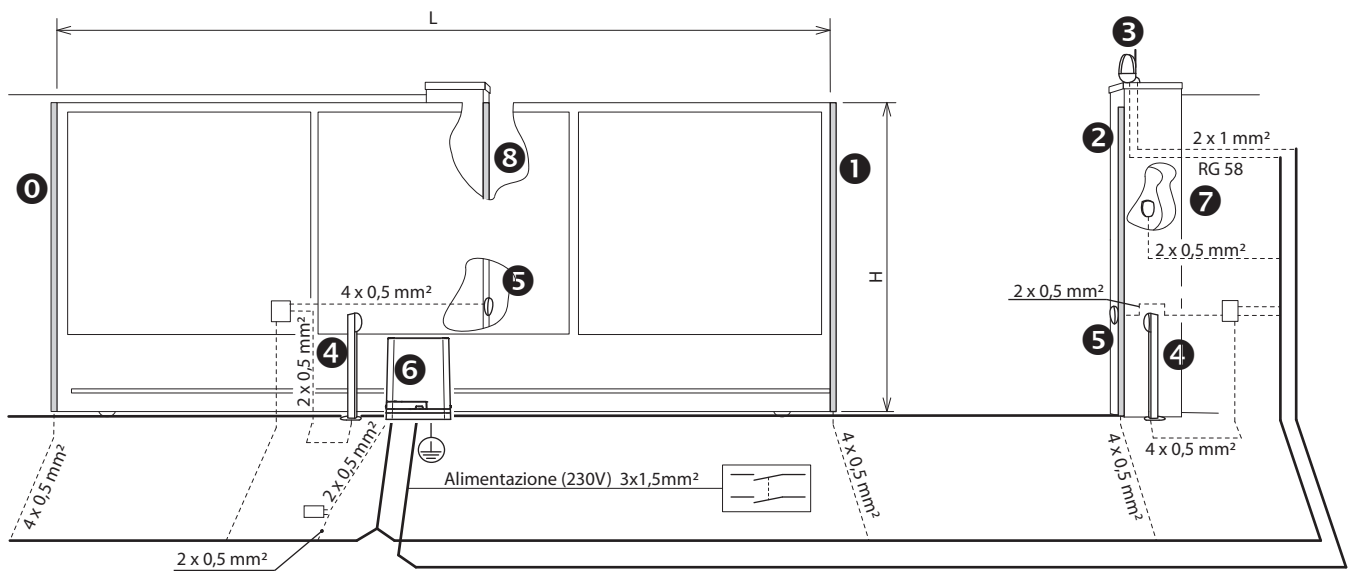

ELECTRICAL CONNECTIONS OF SINGLE COMPONENTS EXECUTED WITH CONTROL BOARD INCORPORATED IN THE MOTOR GROUP OR PLACED IN A WALL FIXED BOX (100G, 100GR, 100GG OR 100A).

Door width
L=

Door height
H=

Approximate door weight
kg=

Documentation produced by DEA System S.p.A. for installation of its products.
DEA doesn't assume any responsibility for errors or damages to items or persons.
© Copyright - All rights reserved - Unauthorized copying, even if partial, prohibited

CROSS THE SQUARES WITH USED COMPONENTS

<p>0 <input type="checkbox"/></p>	<p align="center">Safety Rib</p>	<p><input type="checkbox"/> art. C-16 <input type="checkbox"/> art. 130 <input type="checkbox"/> ...</p>	<p>4 <input type="checkbox"/></p>	<p>Internal photocell: <input type="checkbox"/> art.LINEAR/XS <input type="checkbox"/> art.LINEAR <input type="checkbox"/> art.LINEAR/B <input type="checkbox"/> art.105/N <input type="checkbox"/> art.106/N <input type="checkbox"/> ...</p>						
<p>1 <input type="checkbox"/></p>	<p align="center">Safety Rib</p>	<p><input type="checkbox"/> art. CR-16 <input type="checkbox"/> art. 121N <input type="checkbox"/> ...</p>	<p>5 <input type="checkbox"/></p>	<p>External photocell: <input type="checkbox"/> art.LINEAR/XS <input type="checkbox"/> art.LINEAR <input type="checkbox"/> art.LINEAR/B <input type="checkbox"/> art.105/N <input type="checkbox"/> art.106/N <input type="checkbox"/> ...</p>						
<p>2 <input type="checkbox"/></p>	<p align="center">Safety Rib</p>	<p><input type="checkbox"/> art. CC-16 <input type="checkbox"/> art. 135/2 <input type="checkbox"/> ...</p>	<p>6 <input type="checkbox"/></p>	<table border="1"> <tr> <td data-bbox="928 705 1165 1003"> <p><input type="checkbox"/> serie LIVI/X</p> </td> <td data-bbox="1165 705 1503 1003"> <p><input type="checkbox"/> art.LIVI 6X/M <input type="checkbox"/> art.LIVI 9X/M <input type="checkbox"/> art.LIVI 6X/E/M <input type="checkbox"/> art.LIVI 9X/E/M <input type="checkbox"/> art.LIVI 6/24X/M <input type="checkbox"/> art.LIVI 6/24X/M-BOOST <input type="checkbox"/> art.LIVI 9/24X/M <input type="checkbox"/> art. LIVI 4/24X/M <input type="checkbox"/> ...</p> </td> </tr> <tr> <td data-bbox="928 1003 1165 1288"> <p><input type="checkbox"/> serie REV</p> </td> <td data-bbox="1165 1003 1503 1288"> <p><input type="checkbox"/> art.REV220/M <input type="checkbox"/> art.REV220/RFM <input type="checkbox"/> art.REV24/M <input type="checkbox"/> art.REV24/M BOOST <input type="checkbox"/> art.REV220/IB <input type="checkbox"/> art.REV220/RF/IB <input type="checkbox"/> art.REV24/IB <input type="checkbox"/> ...</p> </td> </tr> <tr> <td data-bbox="928 1288 1165 1639"> <p><input type="checkbox"/> serie GULLIVER/N</p> </td> <td data-bbox="1165 1288 1503 1639"> <p><input type="checkbox"/> art.GULLIVER/N/M <input type="checkbox"/> art.GULLIVER/N/3P/F/M <input type="checkbox"/> art.GULLIVER/N/3P/M <input type="checkbox"/> art.GULLIVER/N/400/3P/M <input type="checkbox"/> art.GULLIVER/N/IB <input type="checkbox"/> art.GULLIVER/N/3P/IB <input type="checkbox"/> ...</p> </td> </tr> </table>	<p><input type="checkbox"/> serie LIVI/X</p>	<p><input type="checkbox"/> art.LIVI 6X/M <input type="checkbox"/> art.LIVI 9X/M <input type="checkbox"/> art.LIVI 6X/E/M <input type="checkbox"/> art.LIVI 9X/E/M <input type="checkbox"/> art.LIVI 6/24X/M <input type="checkbox"/> art.LIVI 6/24X/M-BOOST <input type="checkbox"/> art.LIVI 9/24X/M <input type="checkbox"/> art. LIVI 4/24X/M <input type="checkbox"/> ...</p>	<p><input type="checkbox"/> serie REV</p>	<p><input type="checkbox"/> art.REV220/M <input type="checkbox"/> art.REV220/RFM <input type="checkbox"/> art.REV24/M <input type="checkbox"/> art.REV24/M BOOST <input type="checkbox"/> art.REV220/IB <input type="checkbox"/> art.REV220/RF/IB <input type="checkbox"/> art.REV24/IB <input type="checkbox"/> ...</p>	<p><input type="checkbox"/> serie GULLIVER/N</p>	<p><input type="checkbox"/> art.GULLIVER/N/M <input type="checkbox"/> art.GULLIVER/N/3P/F/M <input type="checkbox"/> art.GULLIVER/N/3P/M <input type="checkbox"/> art.GULLIVER/N/400/3P/M <input type="checkbox"/> art.GULLIVER/N/IB <input type="checkbox"/> art.GULLIVER/N/3P/IB <input type="checkbox"/> ...</p>
<p><input type="checkbox"/> serie LIVI/X</p>	<p><input type="checkbox"/> art.LIVI 6X/M <input type="checkbox"/> art.LIVI 9X/M <input type="checkbox"/> art.LIVI 6X/E/M <input type="checkbox"/> art.LIVI 9X/E/M <input type="checkbox"/> art.LIVI 6/24X/M <input type="checkbox"/> art.LIVI 6/24X/M-BOOST <input type="checkbox"/> art.LIVI 9/24X/M <input type="checkbox"/> art. LIVI 4/24X/M <input type="checkbox"/> ...</p>									
<p><input type="checkbox"/> serie REV</p>	<p><input type="checkbox"/> art.REV220/M <input type="checkbox"/> art.REV220/RFM <input type="checkbox"/> art.REV24/M <input type="checkbox"/> art.REV24/M BOOST <input type="checkbox"/> art.REV220/IB <input type="checkbox"/> art.REV220/RF/IB <input type="checkbox"/> art.REV24/IB <input type="checkbox"/> ...</p>									
<p><input type="checkbox"/> serie GULLIVER/N</p>	<p><input type="checkbox"/> art.GULLIVER/N/M <input type="checkbox"/> art.GULLIVER/N/3P/F/M <input type="checkbox"/> art.GULLIVER/N/3P/M <input type="checkbox"/> art.GULLIVER/N/400/3P/M <input type="checkbox"/> art.GULLIVER/N/IB <input type="checkbox"/> art.GULLIVER/N/3P/IB <input type="checkbox"/> ...</p>									
<p>3 <input type="checkbox"/></p>	<p align="center">Flashing light</p>	<p><input type="checkbox"/> art.AURA/N <input type="checkbox"/> art.LED/B <input type="checkbox"/> ...</p>	<p>7 <input type="checkbox"/></p>	<p><input type="checkbox"/> art.DIGIRAD/N <input type="checkbox"/> art.DIGIKEY/N <input type="checkbox"/> art.102LUX <input type="checkbox"/> art.GT-KEY <input type="checkbox"/> ...</p>						
			<p>8 <input type="checkbox"/></p>	<p align="center">Safety Rib</p> <p><input type="checkbox"/> art. CC-16 <input type="checkbox"/> art. 135/2 <input type="checkbox"/> ...</p>						

MAINTENANCE PROGRAMME

Following a programme of maintenance will ensure the safe and efficient operation of the system. The installer does not accept any responsibility for injury to persons or animals or any damage caused if a proper maintenance programme is not followed. The following details should be documented and retained for future reference

Installing references	Installing firm	Stamp
	Address	
	Installing name and surname	
Door/gate references	Gate owner's name	Unique Identification No.:
	Address	

The frequency of use of the system determines the frequency of maintenance. However this should be no longer than every six months.

ORDINARY MAINTENANCE INSPECTION

Inspection date	Disconnect from electric supply and remove batteries, if fitted <input type="checkbox"/> Check structural parts for any signs of corrosion <input type="checkbox"/> Check all mechanical parts are free from any signs of wear and are adequately greased <input type="checkbox"/> Check that ground stops are present and in good condition therefore preventing derailment / unhooking. <input type="checkbox"/> Check that the manual unlocking system is working properly <input type="checkbox"/> When the system is in the 'unlocked' position check that the door/ gate is sliding/turning properly <input type="checkbox"/> When the system is in the 'unlocked' position check the doors, barriers, or sectional doors are properly balanced <input type="checkbox"/> Check that all screws are securely tightened <input type="checkbox"/> Check all electrical contacts for any sign of corrosion <input type="checkbox"/> Check "O" ring to ensure water is being drained from exit shaft (Ghost 200) <input type="checkbox"/>
Company name	
Signature of technician	Re-Connect power supply <input type="checkbox"/> Check that the power cable is free from defects and in good condition <input type="checkbox"/> Check limit switches (if present) for any defect <input type="checkbox"/> Check correct force adjustment as described from EN 12453 <input type="checkbox"/> Individually check all separate security devices (photo cells, sensitive edges etc.... <input type="checkbox"/>
Signature of customer	
Date of next inspection (This must be determined as part of the maintenance programme)	

ORDINARY MAINTENANCE INSPECTION	
Inspection date	Disconnect from electric supply and remove batteries, if fitted <input type="checkbox"/> Check structural parts for any signs of corrosion <input type="checkbox"/> Check all mechanical parts are free from any signs of wear and are adequately greased <input type="checkbox"/> Check that ground stops are present and in good condition therefore preventing derailment / unhooking. <input type="checkbox"/> Check that the manual unlocking system is working properly <input type="checkbox"/> When the system is in the 'unlocked' position check that the door/ gate is sliding/turning properly <input type="checkbox"/> When the system is in the 'unlocked' position check the doors, barriers, or sectional doors are properly balanced <input type="checkbox"/> Check that all screws are securely tightened <input type="checkbox"/> Check all electrical contacts for any sign of corrosion <input type="checkbox"/> Check "O" ring to ensure water is being drained from exit shaft (Ghost 200) <input type="checkbox"/>
Company name	
Signature of technician	Re-Connect power supply <input type="checkbox"/> Check that the power cable is free from defects and in good condition <input type="checkbox"/> Check limit switches (if present) for any defect <input type="checkbox"/> Check correct force adjustment as described from EN 12453 <input type="checkbox"/> Individually check all separate security devices (photo cells,sensitive edges etc.... <input type="checkbox"/>
Signature of customer	
Date of next inspection (This must be determined as part of the maintenance programme)	

ORDINARY MAINTENANCE INSPECTION	
Inspection date	Disconnect from electric supply and remove batteries, if fitted <input type="checkbox"/> Check structural parts for any signs of corrosion <input type="checkbox"/> Check all mechanical parts are free from any signs of wear and are adequately greased <input type="checkbox"/> Check that ground stops are present and in good condition therefore preventing derailment / unhooking. <input type="checkbox"/> Check that the manual unlocking system is working properly <input type="checkbox"/> When the system is in the 'unlocked' position check that the door/ gate is sliding/turning properly <input type="checkbox"/> When the system is in the 'unlocked' position check the doors, barriers, or sectional doors are properly balanced <input type="checkbox"/> Check that all screws are securely tightened <input type="checkbox"/> Check all electrical contacts for any sign of corrosion <input type="checkbox"/> Check "O" ring to ensure water is being drained from exit shaft (Ghost 200) <input type="checkbox"/>
Company name	
Signature of technician	Re-Connect power supply <input type="checkbox"/> Check that the power cable is free from defects and in good condition <input type="checkbox"/> Check limit switches (if present) for any defect <input type="checkbox"/> Check correct force adjustment as described from EN 12453 <input type="checkbox"/> Individually check all separate security devices (photo cells,sensitive edges etc.... <input type="checkbox"/>
Signature of customer	
Date of next inspection (This must be determined as part of the maintenance programme)	

ORDINARY MAINTENANCE INSPECTION	
Inspection date	Disconnect from electric supply and remove batteries, if fitted <input type="checkbox"/> Check structural parts for any signs of corrosion <input type="checkbox"/> Check all mechanical parts are free from any signs of wear and are adequately greased <input type="checkbox"/> Check that ground stops are present and in good condition therefore preventing derailment / unhooking. <input type="checkbox"/> Check that the manual unlocking system is working properly <input type="checkbox"/> When the system is in the 'unlocked' position check that the door/ gate is sliding/turning properly <input type="checkbox"/> When the system is in the 'unlocked' position check the doors, barriers, or sectional doors are properly balanced <input type="checkbox"/> Check that all screws are securely tightened <input type="checkbox"/> Check all electrical contacts for any sign of corrosion <input type="checkbox"/> Check "O" ring to ensure water is being drained from exit shaft (Ghost 200) <input type="checkbox"/>
Company name	
Signature of technician	
Signature of customer	
Date of next inspection (This must be determined as part of the maintenance programme)	

ORDINARY MAINTENANCE INSPECTION	
Inspection date	Disconnect from electric supply and remove batteries, if fitted <input type="checkbox"/> Check structural parts for any signs of corrosion <input type="checkbox"/> Check all mechanical parts are free from any signs of wear and are adequately greased <input type="checkbox"/> Check that ground stops are present and in good condition therefore preventing derailment / unhooking. <input type="checkbox"/> Check that the manual unlocking system is working properly <input type="checkbox"/> When the system is in the 'unlocked' position check that the door/ gate is sliding/turning properly <input type="checkbox"/> When the system is in the 'unlocked' position check the doors, barriers, or sectional doors are properly balanced <input type="checkbox"/> Check that all screws are securely tightened <input type="checkbox"/> Check all electrical contacts for any sign of corrosion <input type="checkbox"/> Check "O" ring to ensure water is being drained from exit shaft (Ghost 200) <input type="checkbox"/>
Company name	
Signature of technician	
Signature of customer	
Date of next inspection (This must be determined as part of the maintenance programme)	

DECLARATION OF CONFORMITY



In accordance with section II of the **machinery directive 2006/42/CE**

I, the undersigned representative of the following company

Company name	Stamp
Address	

Person authorised to compile the technical file

Name and surname	Address
------------------	---------

Declares that the product named:

Type of automation <input type="checkbox"/> Sliding gate <input type="checkbox"/> Wing gate <input type="checkbox"/> Folding gate <input type="checkbox"/> Sectional door <input type="checkbox"/> Garage door <input type="checkbox"/> Barrier <input type="checkbox"/> ...	Address of installation	
	Unique I.D. no. of unit	Year built
Type of motor	Name of owner	

Is/Are conformable to standards of legislation of the following Directives

- CPR 305/2011 (construction products directive) and subsequent amendments**
- Directive 2006/42/CE (machinery directive) and subsequent amendments**
- Directive 2014/35/EU (low voltage directive) and subsequent amendments**
- Directive 2014/30/EU (EMC directive) and subsequent amendments**
- Directive 2014/53/EU (Radio Equipment Directive RED) and subsequent amendments**

And that the following standards and technical specifications have been applied

- UNI EN 13241-1** Industrial doors and gates : product rule
- UNI EN 12604** Industrial and commercial garage doors and gates, mechanical aspects: requirements
- UNI EN 12453** Industrial and commercial garage doors and gates safety in use of power operated doors: requirements
- UNI EN 12635** Industrial and commercial garage doors and gates installation and use
- UNI EN 12978** "Industrial, commercial and garage doors and gates- Safety in use of power operated doors and gates Requirements and test methods"
- ...

This document becomes invalid when any part of this maintenance register has been disregarded

Place	Date	Legal representatives name	Signature
-------	------	----------------------------	-----------

TEST REPORT

Copy for the installer

Installer data

--

Document number: _____

Product description: _____

B.code: _____

CLIENT or CUSTOMER

First Name		Last Name	
Installation Address (Street, Square, ...)			
ZIP Code	City		Prov.
Phone number		E-mail	

THE PRODUCT IN QUESTION HAS UNDERGONE TESTING WITH A POSITIVE OUTCOME

PRELIMINARY CHECKS

<input type="checkbox"/>	Completeness and integrity of the product
<input type="checkbox"/>	Integrity of intrinsic safety features
<input type="checkbox"/>	Absence of visible defects

ASSEMBLY VERIFICATIONS

<input type="checkbox"/>	Correct assembly of components
<input type="checkbox"/>	Affixing of marking (gate plate)
<input type="checkbox"/>	Mechanical protections
<input type="checkbox"/>	Electrical Hazard Warnings
<input type="checkbox"/>	Mechanical Hazard Warnings
<input type="checkbox"/>	Residual Risk Warnings

FUNCTIONAL VERIFICATIONS

<input type="checkbox"/>	Idle movements in opening and closing
<input type="checkbox"/>	Starting and stopping devices
<input type="checkbox"/>	Emergency devices
<input type="checkbox"/>	Safety devices
<input type="checkbox"/>	Adjustments and settings

PERFORMANCE TESTS

<input type="checkbox"/>	Performance correspondence
<input type="checkbox"/>	Limited and acceptable functional noise
<input type="checkbox"/>	Absence of hazardous emissions
<input type="checkbox"/>	Absence of damage and deformations following the tests

TEST REPORT

Copy for the customer

Installer data

--

Document number: _____

Product description: _____

B.code: _____

CLIENT or CUSTOMER

First Name		Last Name	
Installation Address (Street, Square, ...)			
ZIP Code	City		Prov.
Phone number		E-mail	

THE PRODUCT IN QUESTION HAS UNDERGONE TESTING WITH A POSITIVE OUTCOME

PRELIMINARY CHECKS

<input type="checkbox"/>	Completeness and integrity of the product
<input type="checkbox"/>	Integrity of intrinsic safety features
<input type="checkbox"/>	Absence of visible defects

ASSEMBLY VERIFICATIONS

<input type="checkbox"/>	Correct assembly of components
<input type="checkbox"/>	Affixing of marking (gate plate)
<input type="checkbox"/>	Mechanical protections
<input type="checkbox"/>	Electrical Hazard Warnings
<input type="checkbox"/>	Mechanical Hazard Warnings
<input type="checkbox"/>	Residual Risk Warnings

FUNCTIONAL VERIFICATIONS

<input type="checkbox"/>	Idle movements in opening and closing
<input type="checkbox"/>	Starting and stopping devices
<input type="checkbox"/>	Emergency devices
<input type="checkbox"/>	Safety devices
<input type="checkbox"/>	Adjustments and settings

PERFORMANCE TESTS

<input type="checkbox"/>	Performance correspondence
<input type="checkbox"/>	Limited and acceptable functional noise
<input type="checkbox"/>	Absence of hazardous emissions
<input type="checkbox"/>	Absence of damage and deformations following the tests

Notes:

- The successful completion of the above-described testing procedures constitutes the suitability for the product's use, as well as the formal act of final delivery of the product itself, at its place of installation and use.
- The CE plate applied to the motorized door or gate must be similar to the one indicated below.
- The installing technician fully confirms the measurements and details of all functional verifications and tests mentioned above.
- The Client, by signing this report:
 - Confirms the adequacy and functionality of the product to its specific requirements, as well as its acceptance.
 - Declares to receive the product's instructions for use and maintenance, to review them, and to make them available to all those who will be authorized to use it. Also declares to have received all regulatory information regarding the use in question.
 - Commits to enforcing the correct use of the product and maintaining the appropriate level of good functioning and state of preservation, as specified in the instructions for use.
 - Declares to receive the CE Declaration of Conformity (in compliance with Annex IIA of Directive 2006/42/EC).

(*) REPORT IN THE PLATE ABOVE THE DATA RELATED TO THE SLIDING GATE AS REQUESTED.

Place and date: _____	
Installer's signature: _____	Customer's signature: _____

ACCEPTANCE REPORT

Customer Name:		Stamp with Installer's Details
Address:		
Automatic Closure Description:		
Location:	Identification N°:	

STRUCTURAL CHECKS

	OK, Verified	Repair / Overhaul	NOT Applicable
Solidity and stability of the structure and the mechanical support components (anti-fall)	<input type="checkbox"/>	<input type="checkbox"/>	<input type="checkbox"/>
Condition and wear of wheels/bearings/hinges, or other sliding systems	<input type="checkbox"/>	<input type="checkbox"/>	<input type="checkbox"/>
Condition and securing of the motor or components designated for movement	<input type="checkbox"/>	<input type="checkbox"/>	<input type="checkbox"/>
Condition and solidity of the mechanical end stops (travel limitation of the door/leaf)	<input type="checkbox"/>	<input type="checkbox"/>	<input type="checkbox"/>

SAFETY DEVICE CHECK

	OK, Verified	Repair / Overhaul	NOT Applicable
If installed, check the condition and operation of sensitive edges or safety profiles (active or passive)	<input type="checkbox"/>	<input type="checkbox"/>	<input type="checkbox"/>
If installed, verify the correct functioning of photoelectric, laser, radar barriers... (All type 'E' devices)	<input type="checkbox"/>	<input type="checkbox"/>	<input type="checkbox"/>
Presence of safety clearances around the automation's opening and closing areas	<input type="checkbox"/>	<input type="checkbox"/>	<input type="checkbox"/>
If present, check the condition of safety guards (nets, grilles, rubber profiles, etc.)	<input type="checkbox"/>	<input type="checkbox"/>	<input type="checkbox"/>
Operation and positioning of photocells (internal, external, and additional)	<input type="checkbox"/>	<input type="checkbox"/>	<input type="checkbox"/>
Check the limits of impact or crushing forces	<input type="checkbox"/>	<input type="checkbox"/>	<input type="checkbox"/>

GENERAL CHECKS

	OK, Verified	Repair / Overhaul	NOT Applicable
Condition and operation of the manual/mechanical release for manual opening/closing of the door	<input type="checkbox"/>	<input type="checkbox"/>	<input type="checkbox"/>
If installed, check the operation of the manual opening/closing control/button and ensure it is not located in a hazardous area for the user	<input type="checkbox"/>	<input type="checkbox"/>	<input type="checkbox"/>
If installed, check the condition and operation of the emergency stop control/button	<input type="checkbox"/>	<input type="checkbox"/>	<input type="checkbox"/>
If accessible, check the condition and operation of the main electrical isolator/switch	<input type="checkbox"/>	<input type="checkbox"/>	<input type="checkbox"/>
Check that the drive unit/motor resumes normal operation after a temporary loss of electrical power	<input type="checkbox"/>	<input type="checkbox"/>	<input type="checkbox"/>
If there are thresholds with a height greater than 5/8 mm, check for highlighting and shaping	<input type="checkbox"/>	<input type="checkbox"/>	<input type="checkbox"/>
Condition and operation of courtesy devices (flashing light, buzzer, reflectors, etc.)	<input type="checkbox"/>	<input type="checkbox"/>	<input type="checkbox"/>
Presence and condition of the CE marking plate	<input type="checkbox"/>	<input type="checkbox"/>	<input type="checkbox"/>
Presence of technical documentation (Technical File, Maintenance Register, etc.)	<input type="checkbox"/>	<input type="checkbox"/>	<input type="checkbox"/>

ADDITIONAL NOTES

For Acceptance

For Acknowledgment

Date:	Customer Signature:	Installer Signature:
--------------	----------------------------	-----------------------------

This document does not relieve the manufacturer of their responsibilities.